

HIGH POWER FSK TRANSMITTER

869.525 MHz – 50 Ω

P.n. 3-2001068

PRELIMINARY

**DESCRIPTION :**

High Power FSK transmitter operating in the 868.4-868.65MHz band, manufactured on SMT technology. Delivering +27dBm on a well-matched 50 Ohm load, the module is ideal for both narrowband or wideband applications where high link budgets are needed.

HIGHLIGHTS:

High output power with high frequency stability over voltage and temperature variations. Thanks to the Tx Enable function, the module can be completely turned off, avoiding current consumption in power down mode. Due to its architecture the module is ideally suited to narrowband standards and particularly those that stipulate 12.5kHz and 25kHz channel separation. Gaussian transmit data filtering option (GFSK) improves spectral efficiency for narrow-band applications. Developed according to I-ETS 300 220 and ETS 300 683 European Standard.

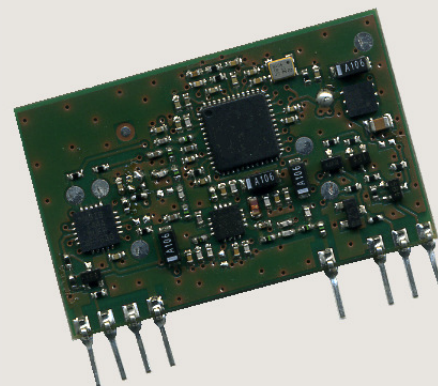
**APPLICATIONS:**

Industrial applications, Surveillance Systems, Data Transmission.

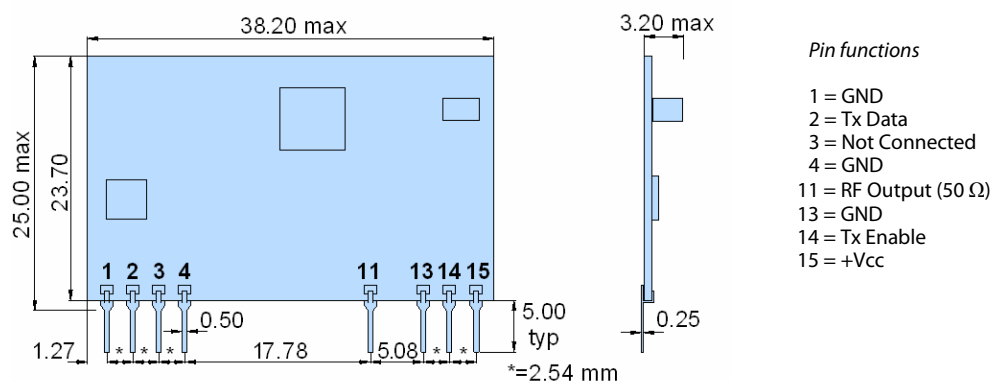
MECHANICAL CHARACTERISTICS:**ABSOLUTE MAX. RATINGS**

Power supply, +Vcc, pin 15:	+ 7.0 Volt
Storage temperature:	- 40 ÷ + 100 °C
Operating temperature:	- 20 ÷ + 70 °C

ELECTRICAL CHARACTERISTICS AT + 25 °C

Parameter	Min.	Typ.	Max.	Unit	Note
Supply voltage (+Vcc)	4.5	5.0	6.0	Volt	
Current consumption	-	650	-	mA	Note 1
Transmission frequency	-	869.525	-	MHz	
Centre frequency stability over temperature - 20 ÷ + 70 °C	-	± 1.0	-	kHz	
FSK Modulation	-	± 15	-	kHz	Note 2
Power Output (50 Ω load)	-	+ 27	-	dBm	
Second harmonic level (50 Ω load)	-	-	- 30	dBm	
Start up time (T _{ON})	-	-	30	ms	
Power off time (T _{OFF})	-	-	50	ms	

Mipot S.p.a. reserves the right to modify the specifications without notice.

Cormòns, 02.09.2010

ELECTRICAL CHARACTERISTICS AT + 25 °C

Parameter	Min.	Typ.	Max.	Unit	Note
"0" Low logic level	-0.5	-	0.4	Volt	
"1" High logic level	3.3	-	6.0	Volt	
Data rate	-	4800	-	Baud	Note 3

TIMINGS

To assure correct operation during power-up and power-down sequences, a minimum time between Enable and data transmission should be maintained.

As showed on the following picture, a minimum time T_{ON} higher than 30ms has to be assured between Tx Enable activation and forwarding of data to be transmitted on Tx Data line (pin 2), this to allow correct start-up of the tx circuitry. During power-off sequence, a minimum time T_{OFF} higher than 50ms, has to be guaranteed between the high-to-low transition of the Tx Enable line and a new transmitter activation (bringing Tx Enable line high again); this is mandatory to allow power-down of the transmitter correctly.

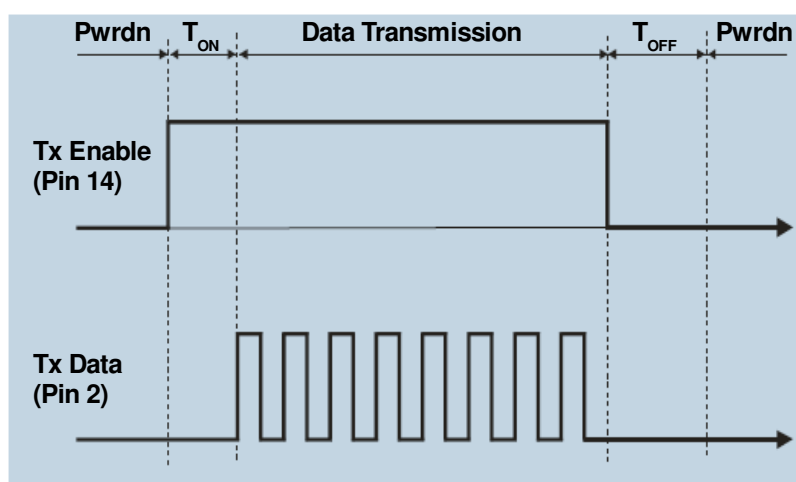

Note 1: This is the typical current consumption when a well-matched 50 Ohm load is applied to the RF output (pin 11) of the module; a good matched condition into a 50 Ohm load has to be assured in order to avoid over-currents due to power reflections by mismatched loads which could irreversibly lead to module damage.

Note 2: The default deviation setting is for wideband application in the band 868.4 – 868.65 MHz but, on request, it can be modified to allow narrowband applications on 25kHz or 12.5kHz channel separation.

Note 3: The data rate as reported on the datasheet refers to a default setting for wideband application. For narrowband applications its value has to be set accordingly to the chosen channel separation.

Note 4: All RF parameters measured with RF output (pin 11) connected to 50 Ohm impedance load.

MIPOT S.P.A.

Via Corona, n.5
(Zona Ind.)
34701 Cormons (GO)
Italy
Tel. +39 0481 630200 ra.
Fax +39 0481 62387
mipot@mipot.com