

434.010MHz NARROW BAND 25 kHz FSK RECEIVER

p.n. 3-2000773

Description: Super Heterodyne Narrow band 25 kHz FSK Receiver, manufactured in SMT technology on glass-epoxy laminate.

Highlights: Digital anti-glitch filter to optimize RF performances, front end SAW filter to improve out of band rejection, a TCXO reference oscillator to guarantee frequency stability in time and temperature.

Developed according to I-ETS 300 220.

Applications: Security Systems, Social Alarms.

Mechanical characteristics:

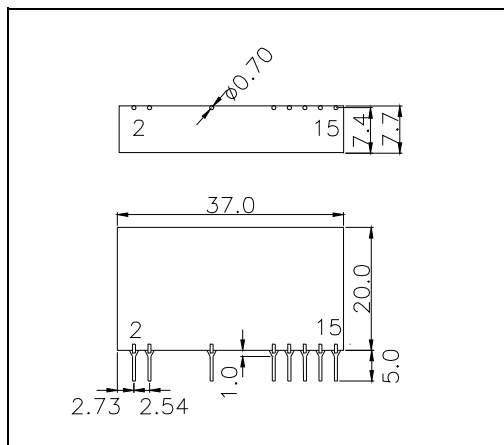

PIN FUNCTIONS

- 2 = GND
- 3 = RF Input (50Ω)
- 7 = GND
- 11 = GND
- 12 = +RX Enable (+Vcc, if not used)
- 13 = RSSI OUT
- 14 = TTL Out
- 15 = +Vcc

Abs. Max. Ratings:

- Power Supply, Vcc, pin 12, 15 : + 6 Volt
- Radio Frequency Input, pin 3 : +10 dBm
- Voltage, with respect to GND of output pins : +Vcc
- Storage Temperature : 0 ÷ + 55 °C

Electrical Characteristics at + 25°C:

Parameter	Min.	Typ.	Max	Unit	Note
Power Supply (Vcc)	2.7	-	5.5	Volt	
Supply Current (+RX En = High)	-	-	11	mA	
Power Down Supply Current (+RX En = Low)	-	-	<0.1	uA	Note 2
Receive Frequency	-	434.010	-	MHz	
Sensitivity (FSK±2.5kHz square wave 1 kHz)	-100	-	-	dBm	
S/N Ratio at -100 dBm	19	-	-	dB	
RF Bandwidth at -3 dB	4.5	-	-	kHz	
Frequency deviation demodulation	±1.5	-	±3.0	kHz	
Adjacent channel rejection (25kHz)	25	-	-	dB	
Image Frequency Rejection	35	-	-	dB	
Logic Low	GND	-	0.05	Volt	
Logic High	+Vcc	-	-	Volt	
Power ON time	-	-	20	msec	
Max Baud Rate	-	-	2400	Baud	
AF Output Impedance (pin 14)	-	-	100	KΩ	

Note 1.: all RF parameters measured with the input connected to a 50Ω impeded. signal source or load
 Note 2.: in power-down mode the TTL Output (pin 14) is high



434.010MHz NARROW BAND 25 kHz FSK RECEIVER

p.n. 3-2000773

RSSI VOLTAGE LEVEL TABLE

The RSSI Output (pin 13) provides a relationship between the voltage level and the RF signal. The below table express the relation between the voltage value and the RF signal, notice that there is a variation in the absolute value of the RSSI voltage versus RF signal, therefore the absolute value is not an accurate indication of the signal level.

The slope of the curve (the increment from one level to another) is relatively constant.

RF Signal (dBm)	Receiver #1	Receiver #2	Typical voltage increment
	RSSI Level(V)	RSSI Level(V)	(mV)
None	0.4	1.09	-
-100	0.68	1.36	280 mV
-90	0.94	1.6	250 mV
-80	1.16	1.78	200 mV
-70	1.37	1.94	200 mV
-60	1.55	2.08	160 mV
-50	1.71	2.22	150 mV

To have a quite correct indication of the RF signal strength it is suggest to connect the receiver to a 50 Ohm load and measure the RSSI level without a RF signal applied at the input, after this looking at the increments of the above table it is possible to recover the RF signal at the input of the receiver.

Mipot S.p.A - Via Corona, 5 - Z.I.
34071 CORMONS (GO)
ITALY

Tel (+39) 0481 - 630200
Fax (+39) 0481 - 62387
e-mail: mipot@mipot.com
www.mipot.com

Mipot S.p.A. reserves the right to modify the specifications without notice.

Cormòns, July '06