

2.4 GHz MULTICHANNEL TRANSCEIVER

Cod. 3-2000771

PRELIMINARY**DESCRIPTION:**

The 3-2000771 module is a multichannel transceiver operating in the 2.4 GHz ISM Band, it is based on the Freescale MC13192 RF IC, it has integrated on board a PIFA (Planar Inverted F Antenna), an RF switch and is interfaced to the external world with a 14 pins strip connector.

The module could be connected to an external microcontroller through an SPI interface.

The transceiver operates in the 2.4 GHz band and is compatible with the IEEE 802.15.4 Standard and so it is able to support hardware requests from a Zigbee node.

MAIN CHARACTERISTICS:

- 16 channels with 5 MHz spacing (from 2.405GHz to 2.480GHz)
- Direct Sequence Spread Spectrum (DSSS)
- O-QPSK Modulation (Offset-Quadrature Phase Shift Keying)
- 250 kbps baud rate

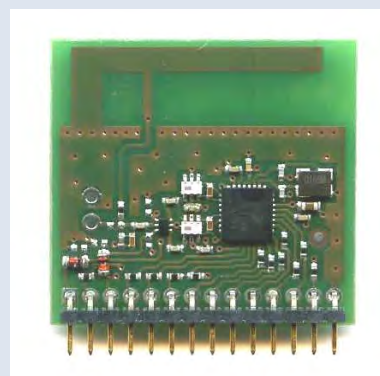
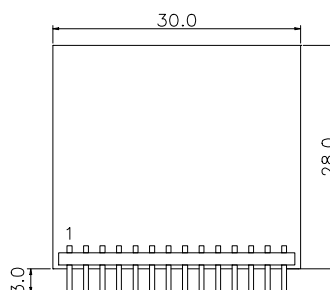
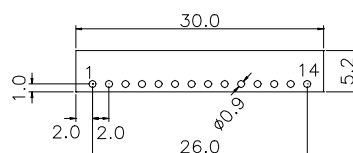
**MECHANICAL CHARACTERISTICS****PIN DESCRIPTION**

Pin	Name	Description
1	SWITCH	RF switch command pin High Level = Transmission Mode Low Level = Reception Mode
2	GPIO2	General purpose pin. Could be used like an indicator for a valid CRC
3	+Vcc SWITCH	Switch supply voltage pin
4	RSTB	Reset (active low)
5	RXTXEN	Input pin for the setup of the TX and RX sequences
6	ATTNB	Wake-up pin from the "Hibernate" and "Doze" mode (low power modes)
7	CLKO	Output from the TRX - Programmable Clock
8	SPICLK	SPI: input clock
9	MOSI	SPI: Master Out/Slave In
10	MISO	SPI: Master In/Slave Out
11	CEB	SPI: Chip Select. Active Low
12	IRQB	Output pin for Interrupt signalling. Active Low
13	VDD	Supply voltage pin
14	GND	Ground (0V)

For setup of MC13192 and internal registers functionality refer to online documentation of the product on Freescale website. The documentation is downloadable from the following link:

http://www.freescale.com/webapp/sps/site/prod_summary.jsp?code=MC13192&nodeld=01J4Fs25658166

The RF switch is the NEC uPG2012TK and the datasheet is downloadable from:

<http://www.ncsd.necel.com/microwave/english/ic/switch.html>

APPLICATIONS	ABS. MAX. RATINGS	
• POS (Point Of Sale)	Transceiver Supply +Vdd (pin 13)	+ 3.6 V
• Bar code readers	Applied voltage on pins 1 - 13	+ 3.6 V
• Wireless modem	Operating Temperature	from - 20 to + 70° C
• Portable Equipment	Storage Temperature	from - 40 to + 120° C
• Audio transmission		
• Remote control		

ELECTRICAL CHARACTERISTICS (SEE NOTE 1)					
Parameter	Min.	Typ.	Max.	Unit	
Transceiver Supply Voltage +Vcc (pin 11)	2.7	3.0	3.4	V	
Current Consumption	Off	-	1.0	μA	
	Hibernate	-	6.0	μA	
	Doze	-	110	μA	
	Idle	-	500	μA	
	Transmission	-	30	35	mA
	Reception	-	37	42	mA
Vlow on I/O pins	0		0.2*Vcc	V	
Vhigh on I/O pins	0.8*Vcc		+ Vcc	V	
Electrical characteristics of the receiver:					
Sensitivity (1% Packet Error Rate)		-92		dBm	
Adjacent Channel Rejection (+5MHz)		25		dB	
Adjacent Channel Rejection (-5MHz)		31		dB	
Alternate Channel Rejection (+10MHz)		42		dB	
Alternate Channel Rejection (-10MHz)		41		dB	
Electrical characteristics of the transmitter:					
Output Power	-3	0	+3	dBm	
Baud rate		250		kbps	
Radiated Spurious Emissions	Within I-ETS-300-220 limits				

Note 1: All the RF parameters are measured connecting the RF input/output (TP RF) to a 50 Ohm load and disconnecting the integrated antenna.

CIRCUIT SCHEMATIC

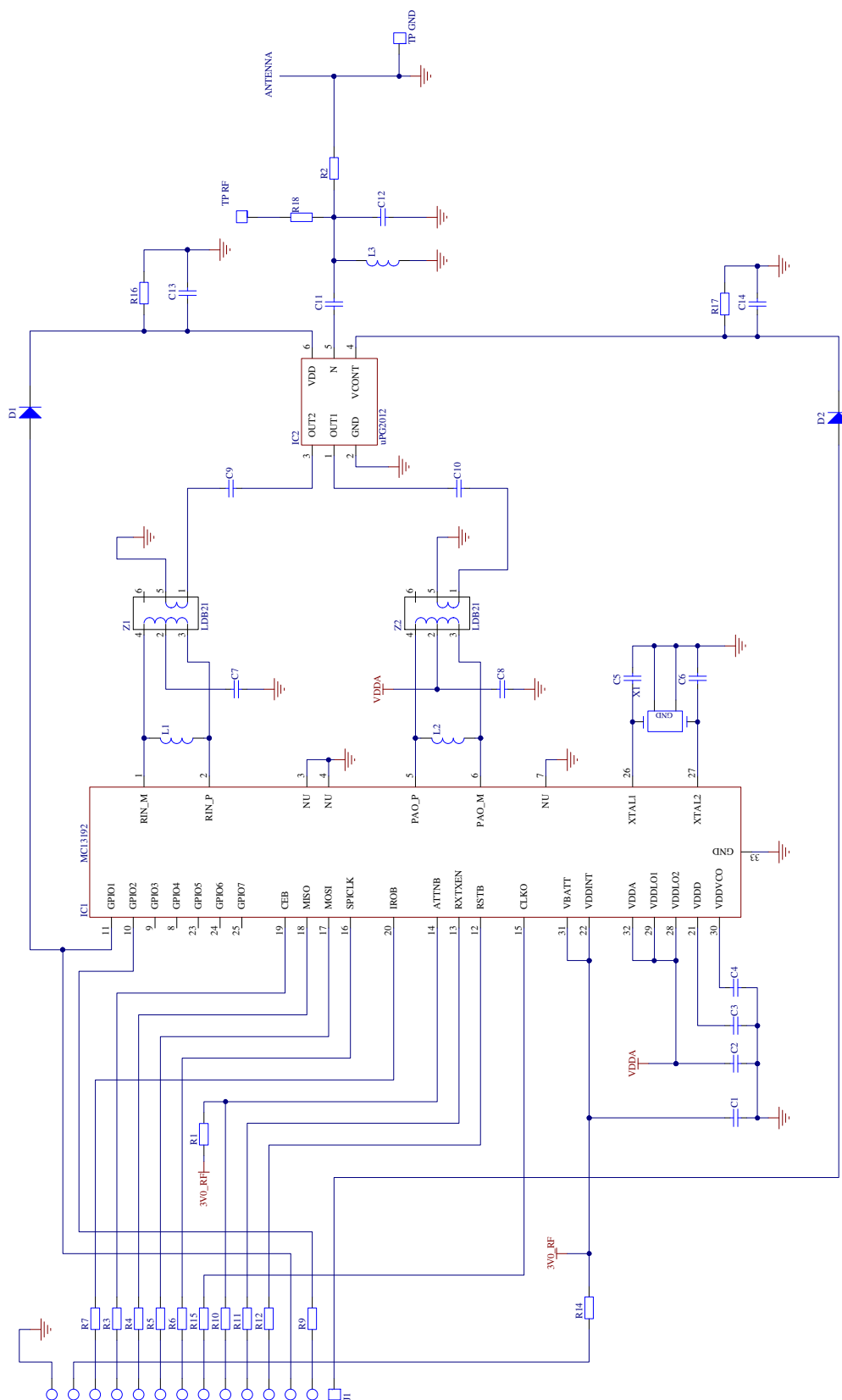

RF WIRELESS



MIPOT
HI-TECH COMPANY

MIPOT S.P.A.
Via Corona, n.5
(Zona Ind.)
34701 Cormons (GO)
Italy
Tel. +39 0481 630200 ra.
Fax +39 0481 62387
mipot@mipot.com